

# TUNING FORK VIBRATING LEVEL SWITCH

**MODEL AI.VLS5500**



# TECHNICAL DATA

**Housing: IP65**

**Explosion Proof:**

**Class I, Groups B, C, D;**

**Class II, Groups E, F, G; NEMA 4X**

VLS5500 Series are assembled with a tuning fork and energized sensor. It vibrates frequently with mechanical resonance to detect level of powders or granular bulk solids.

**Using in powder or solids**

**Wetted part material:** 316 stainless steel

**Thread connection:** 2" NPT, 2" BSP

**Flange connection:** from 2" to 3", JIS, ANSI, DIN available

**Detection length:**

	Minimum	Maximum
Thread	200mm	450mm
Flange	245mm	450mm

**Working temperature:** -30°C~+80°C

**Working pressure:** maximum 100 kg/cm<sup>2</sup>, up to 400 kg/cm<sup>2</sup> on request

**Liquid viscosity:** 0.2~10000 mpas

**Liquid density:** 0.6 g/cm<sup>3</sup>~2.5 g/cm<sup>3</sup>

**Housing:** IP65

**Explosion Proof:** Class I, Groups B, C, D; Class II, Groups E, F, G; NEMA 4X

**Power Supply:** 110VAC, 220VAC, 24VDC

**Contact Form:** SPDT

**Contact Rating:** 20A/125VAC, 12A/250VAC

## HOUSING DIMENSIONS

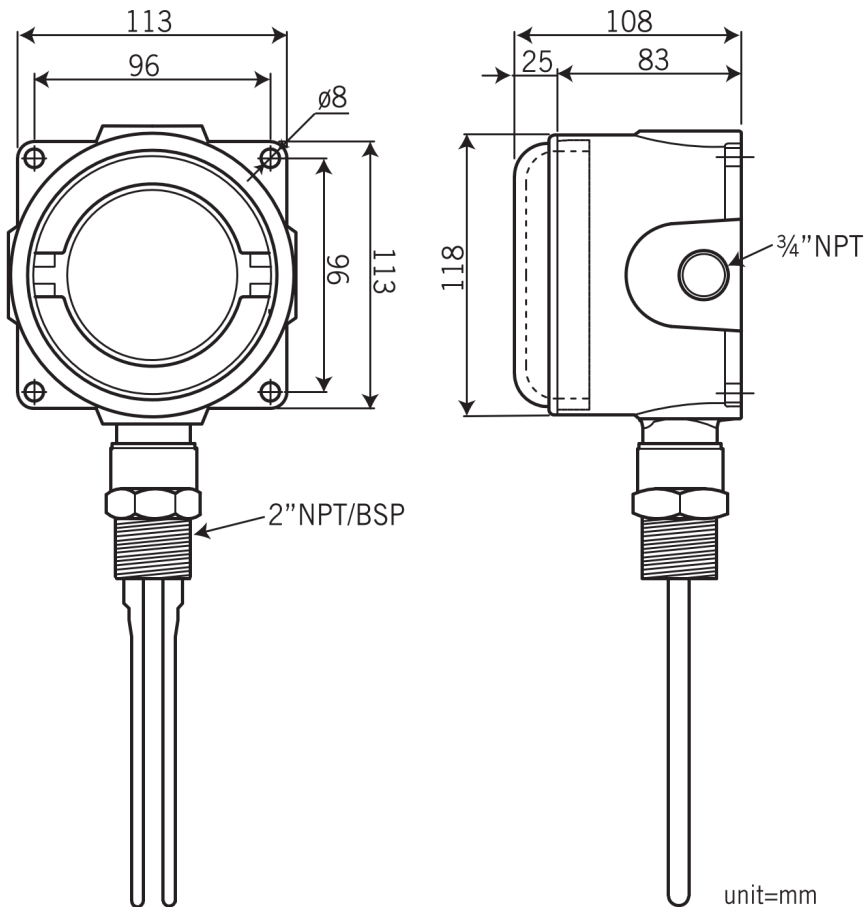

## APPLICATION AND INSTALLATION

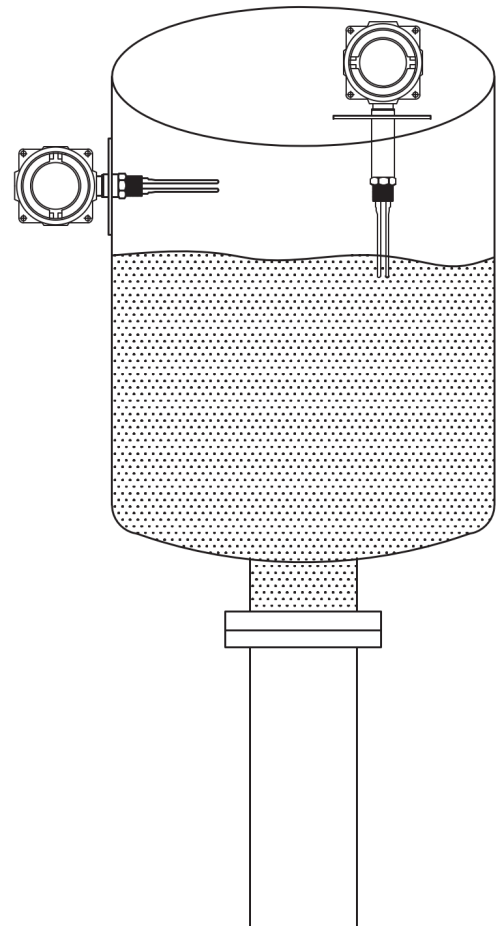

# PROCESS CONNECTION

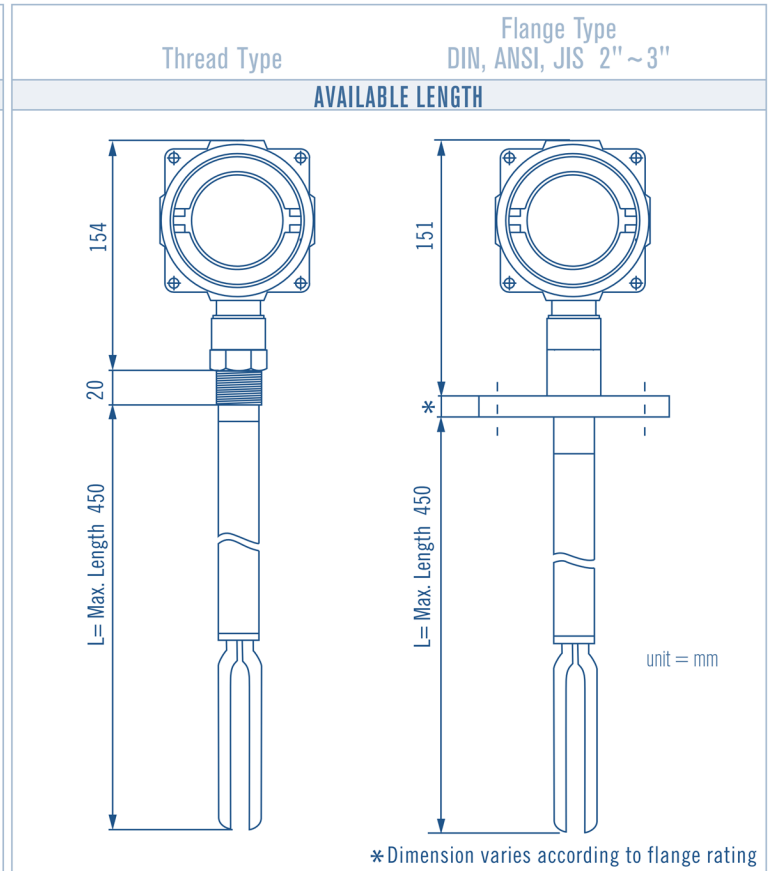
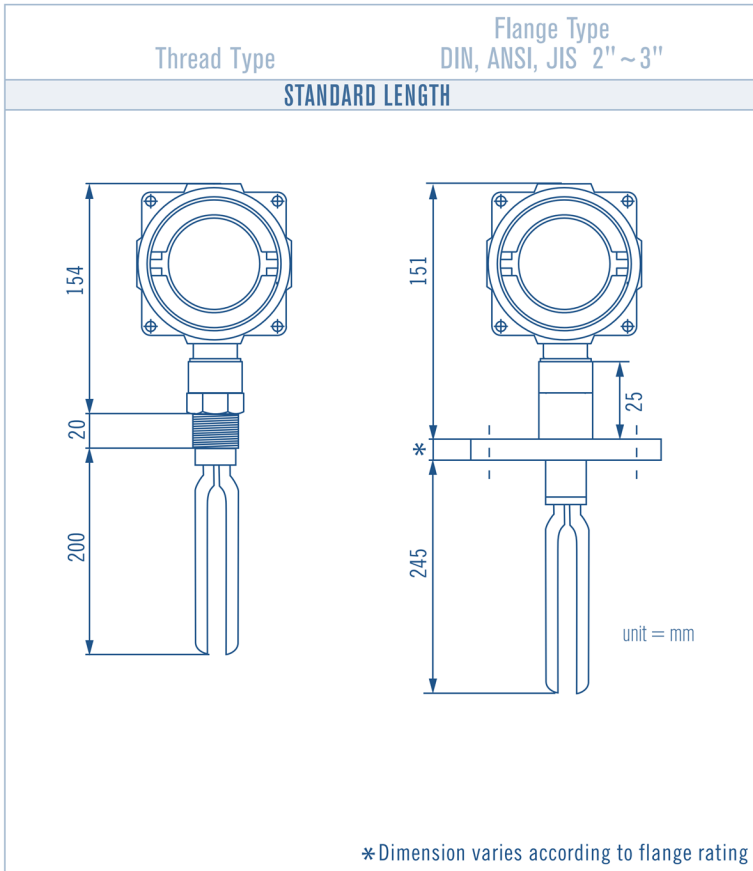

# ORDERING INFORMATION

VLS5500	Code	Process Connection
		(1) Thread type (2) Flange type
	<b>Code</b>	<b>Connection Size</b>
		(A) 2" (B) 3"
	<b>Code</b>	<b>Connection Rating</b>
		Thread: (1) NPT (2) BSP Flange: (3) JIS10K (4) JIS20K (5) ANSI 150# (6) ANSI 300# (7) PN10 (8) PN16 (9) PN25 (0) Option: fill in the requested rating _____
	<b>Code</b>	<b>Electronic Connection</b>
		(E) ¾"NPT Female, Standard (F) ½"NPT Female
	<b>Code</b>	<b>Insertion Length</b>
	S	Standard
	L	Fill in the requested length ie: L=300mm
	<b>Code</b>	<b>Power Supply</b>
		(A) 110VAC (B) 220VAC (C) 24VDC
VLS5500		<b>Complete Ordering Code</b>



# ASIT ITALIA S.R.L.

Sede operativa e Uffici  
Via Quintino Sella, 6  
10020 Riva presso Chieri (TO)  
T (+39) 011 198 218 39 - F (+39) 011 198 371 06

[INFO@ASIT-GE.COM](mailto:INFO@ASIT-GE.COM)

[WWW.ASIT-GE.COM](http://WWW.ASIT-GE.COM)



Company with  
Certificate of Quality  
System ISO 9001:2015  
Cert n°38785/19/S